

MANUAL ADDENDUM

M200EU

NOy CONVERTER OPTION

Teledyne Advanced Pollution Instrumentation
9480 Carroll Park Dr.
San Diego, CA 92121-5201

TOLL-FREE: 800-324-5190
FAX: 858-657-9818
TEL: 858-657-9800
E-MAIL: api-sales@teledyne.com
WEB SITE: www.teledyne-api.com

SAFETY MESSAGES

Your safety and the safety of others is very important. We have provided many important safety messages in this manual. Please read these messages carefully.

A safety message alerts you to potential hazards that could hurt you or others. Each safety message is associated with a safety alert symbol. These symbols are found in the manual and inside the instrument. The definition of these symbols is described below:



General Warning/ Caution: Refer to the instructions for details on the specific danger.



Hot Surface Warning



Electrical Shock Hazard



Technician Symbol: All operations marked with this symbol are to be performed by qualified maintenance personnel only.



Electrical Ground: This symbol inside the instrument marks the central safety grounding point for the instrument.



CAUTION

The analyzer should only be used for the purpose and in the manner described in this manual.

If you use the analyzer in a manner other than that for which it was intended, unpredictable behavior could ensue with possibly hazardous consequences.

Table of Contents

SAFETY MESSAGES

Table of Contents

List of Figures

List of Tables

1.0 GETTING STARTED

1.1 Unpacking

1.2 Electrical and Pneumatic Connections

1.3 Initial Operation

2.0 SPECIFICATIONS, WARRANTY

2.1 Specifications

2.2 Warranty

3.0 THE M501Y NOY CONVERTER

3.1 Principle of Operation

4.0 CALIBRATION AND ZERO/SPAN CHECKS

4.1 Calibration or Cal Check Procedure

5.0 MAINTENANCE

5.1 Maintenance Schedule

5.2 Replacing the Sample Particulate Filter

5.3 Check Bypass Flow Rates

5.4 Replacing the Converter

5.5 Pneumatic Line Inspection

5.6 Leak Check Procedure

6.0 TROUBLESHOOTING, ADJUSTMENTS

6.0.1 General Troubleshooting Hints

Model 200EU-NOy Option Manual Addendum

6.1 Operation Verification - M501Y Diagnostic Techniques

6.1.1 Pneumatic System

6.1.2 Leak Check

6.1.3 Bypass Pump Diagnostic Procedures

6.1.4 Electrical Fault Isolation

6.2 Setting the Converter Temperature

6.1.4 Temperature Controller Setup

7.0 M501Y SPARE PARTS LIST

List of Figures

FIGURE 1.1 - REAR PANEL PNEUMATIC CONNECTIONS	8
FIGURE 5.1 - REPLACING THE PARTICULATE FILTER	21
FIGURE 5.2 - CONVERTER ASSEMBLY	23
FIGURE 5.3- PNEUMATICS DIAGRAM (STANDARD AND Z/S OPTION)	25
FIGURE 5.4: PNEUMATIC DIAGRAM (OPT 86 OPTION)	26
FIGURE 6.1 – ELECTRICAL DIAGRAM.....	32

List of Tables

TABLE 2.1 - FINAL TEST AND CALIBRATION VALUES

TABLE 4.1 - MANUAL ZERO CALIBRATION PROCEDURE - ZERO GAS THRU SAMPLE PORT

TABLE 4.2 - ENTER EXPECTED SPAN GAS CONCENTRATIONS PROCEDURE

TABLE 4.3 - SPAN CALIBRATION PROCEDURE

TABLE 5.1- PREVENTATIVE MAINTENANCE CALENDAR

TABLE 6.1 – TEMPERATURE CONTROLLER PROGRAMMING GUIDE

1.0 Getting Started

The M501Y has been designed to operate with the M200EU low level NOx analyzer.

1.1 Unpacking

1. The M200EU with NOy Option comes in three boxes.
 - The M200EU analyzer
 - The Bypass Pump Chassis
 - The External Converter and umbilical cable assembly
2. Verify that there is no apparent shipping damage. If damage has occurred please advise shipper first, then API.

CAUTION

To avoid personal injury, always use **two** persons to lift and carry the Model 501 Pump Pack Chassis.



3. Before operation of the M200EU, remove the shipping screws as shown in the M200E/EU Manual.
4. Please check the voltage and frequency label on the rear panel of the instrument for compatibility with the local power before plugging in the M501Y.

1.2 Electrical and Pneumatic Connections

1. Mount the converter on a suitable mast outside of the enclosure.
2. Route the umbilical cable assembly into the shelter.
3. Locate the M200EU and M501Y Bypass Pump Chassis in close proximity, preferably mounting one over the other in a 19" rack.
4. Connect the electrical/pneumatic cable fittings to the rear of the Bypass Pump Chassis. Use the tags on each tube and Figure 1.1 to match up the correct tube with the rear panel bulkhead fitting. Please note that the dashed lines show optional Zero/Span Valve configuration connections.
5. Connect the 7-pin power and signal cable to the connector on the rear of the Bypass Pump Chassis.
6. Connect the power cord to the correct line voltage.

WARNING

- **Lethal voltages are present inside case**
- **Do not operate with cover off during normal operation**
- **Before operation, check for correct input voltage and frequency.**
- **Do not operate without proper chassis grounding**
- **Do not defeat the ground wire on power plug**
- **Turn off power before disconnecting electrical subassemblies**



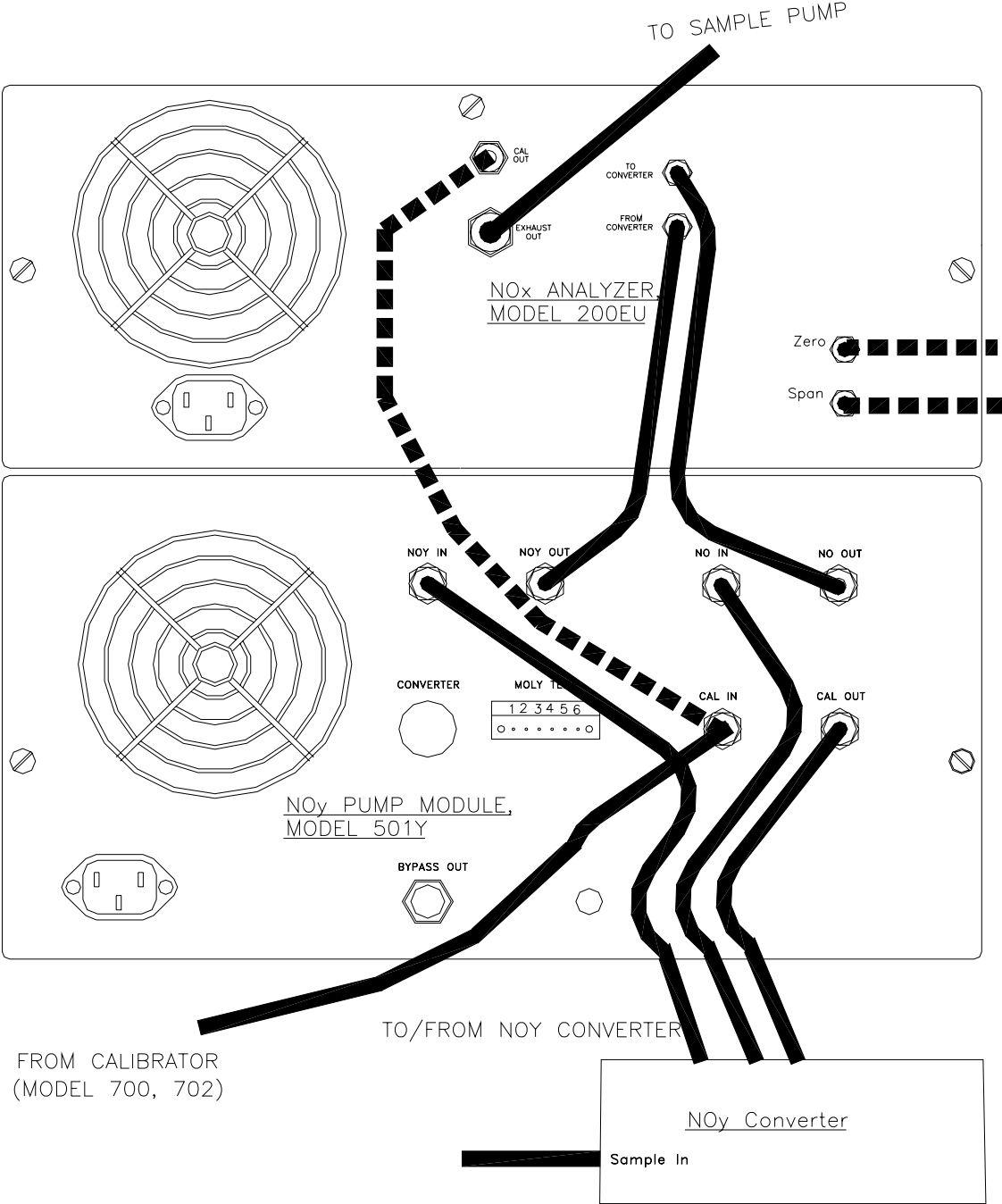

Figure 1.1 - Rear Panel Pneumatic Connections

1.3 Initial Operation

1. After confirming proper supply voltage, turn on the instrument power. If you are unfamiliar with the M200EU with NOy Option, we recommend that you read the overview in Section 3 before proceeding.
2. The power indicator light and display should immediately light, in addition the bypass pump should start up. The M501Y requires about 30 minutes for the converter to come up to temperature.
3. While the converter is coming up to temperature, the M200EU should be powered-up also. Follow the instructions in the M200E/EU Manual to confirm proper operation of that instrument. Note: It will take 30 minutes for the ozone generator to start up in the M200EU. During that time the instrument will not respond to span gas.
4. After 30 min, the display on the Bypass Pump Chassis should read 315°C, indicating that the converter is up to temperature.
5. Proceed to Section 4 of this manual to do a zero/span check.

Table 2.1 - Final Test and Calibration Values

Test Values	Observed Value	Units	Nominal Range
CONVERTER TEMP		°C	315 ±7
BYPASS FLOW – NO CHANNEL		CC/MIN	1100 ± 200
BYPASS FLOW – NO _x CHANNEL		CC/MIN	1100 ± 200

Converter Serial # _____

Date _____

Technician _____

2.0 Specifications, Warranty

2.1 Specifications

Converter	Remotely mounted molybdenum converter with temperature controller in a NEMA – 4 enclosure.
Converter Temperature	315°C ± 7°C with read-out on front panel of bypass pump chassis.
Tube/Electrical Cable Assembly	Up to 50 feet (15 m) maximum length
Power, Bypass Pump Assembly	120V~ 60 Hz, 230V~ 50 Hz 360 watts
Power, Converter Assembly	120V~ 50/60 Hz, 60 watts
Converter Efficiency	>96% for NO2
Weight, Bypass Pump Assembly	35 lbs (16 kg)
Weight, Remote Converter	30 lbs (11 kg)
Bypass Pump Chassis Dimensions HxWxD	9" x17" x23.6" (23cm x 43cm x 61cm)
Remote Converter Assy Dimensions HxWxD	12"x19"x7" (31cm x 48cm x 18cm)
Environmental	Installation Category (Over-voltage Category) II Pollution Degree 2
Bypass Flowrate Cal gas Flowrate	1100 cc/min ± 20%, each channel 4000 cc/min (approx.)
Analog output	Converter temp analog output. 3.15 VDC = 315°C

2.2 Warranty

ADVANCED POLLUTION INSTRUMENTATION, INC.

02024c

Prior to shipment, API equipment is thoroughly inspected and tested. Should equipment failure occur, API assures its customers that prompt service and support will be available.

COVERAGE

After the warranty period and throughout the equipment lifetime, API stands ready to provide on-site or in-plant service at reasonable rates similar to those of other manufacturers in the industry. All maintenance and the first level of field troubleshooting are to be performed by the customer.

NON-API MANUFACTURED EQUIPMENT

Equipment provided but not manufactured by API is warranted and will be repaired to the extent and according to the current terms and conditions of the respective equipment manufacturers warranty.

GENERAL

API warrants each Product manufactured by API to be free from defects in material and workmanship under normal use and service for a period of one year from the date of delivery. All replacement parts and repairs are warranted for 90 days after the purchase.

If a Product fails to conform to its specifications within the warranty period, API shall correct such defect by, in API's discretion, repairing or replacing such defective Product or refunding the purchase price of such Product.

The warranties set forth in this section shall be of no force or effect with respect to any Product:

(i) that has been altered or subjected to misuse, negligence or accident, or (ii) that has been used in any manner other than in accordance with the instruction provided by API or (iii) not properly maintained.

THE WARRANTIES SET FORTH IN THIS SECTION AND THE REMEDIES THEREFORE ARE EXCLUSIVE AND IN LIEU OF ANY IMPLIED WARRANTIES OF MERCHANTABILITY, FITNESS FOR PARTICULAR PURPOSE OR OTHER WARRANTY OF QUALITY, WHETHER EXPRESSED OR IMPLIED. THE REMEDIES SET FORTH IN THIS SECTION ARE THE EXCLUSIVE REMEDIES FOR BREACH OF ANY WARRANTY CONTAINED HEREIN. API SHALL NOT BE LIABLE FOR ANY INCIDENTAL OR CONSEQUENTIAL DAMAGES ARISING OUT OF OR RELATED TO THIS AGREEMENT OF API'S PERFORMANCE HEREUNDER, WHETHER FOR BREACH OF WARRANTY OR OTHERWISE.

TERMS AND CONDITIONS

All units or components returned to API should be properly packed for handling and returned freight prepaid to the nearest designated Service Center. After the repair, the equipment will be returned, freight prepaid.

3.0 The M501Y NOy Converter

3.1 Principle of Operation

The API Model 200EU with NOy Option is designed to measure the concentration of NO, NO₂, and other compounds that are too unstable to be measured when taken in through the normal ambient air sample inlet system. Please refer to the M200EU manual supplied with this system for a general discussion of the operation of a NO_x analyzer. The suite of compounds known collectively as NO_y is composed of roughly 30 compounds. There is some disagreement over whether certain compounds should be on the list. The NO_y measurement is generally done in conjunction with a standard NO_x measurement, with the difference between the two being the concentration of the unstable compounds, sometimes referred to as NO_z.

The system is composed of 3 modules:

- The M200EU, without a moly converter
- A Bypass pump chassis containing:
 - Bypass pump
 - Flow control
 - Sample filtration
 - Moly temperature control
 - Pneumatic provisions for calibration
- An externally mounted molybdenum converter

The M200EU w/NOy Option system allows the converter to be mounted at the sample inlet point. This configuration provides minimal time delay between the sample inlet port and the remotely mounted molybdenum converter. Minimizing the transit time between the sample inlet and converter enables the conversion of labile components of NO_y. The equation for the conversion is:

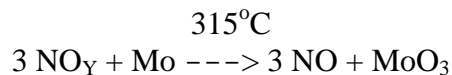

4.0 CALIBRATION AND ZERO/SPAN CHECKS

Unlike most NO_x analyzers, the M200EU with the NO_y option does not have a sample inlet port on the rear panel of the 200EU. The sample port is located on the External Converter; therefore zero/span calibration is different than a normal NO_x instrument.

Follow the steps in the M200E/EU manual to:

- a. Enter the expected NO and NO_x span gas concentrations in the M200EU.
- b. Do the zero calibration procedure
- c. Do the span calibration procedure

The analyzer always routes the zero/span gas through the external converter. In standard configuration, the calibration gas needs to be input at the “Cal in” port of the M501 Pump pack. When Zero/Span valve option is installed, zero and span gases are to be provided at the 200EU zero and span ports. In all cases, the calibration gas delivered must be under a small amount of pressure (2-5 psig) to overcome the resistance of the hoses. Also, there must be no venting of the zero or span gas to atmosphere.

Calibration gas must be provided for both the bypass system and the 200EU analyzer. Flow requirements are 1.1 LPM for NO bypass, 1.1 LPM for NO_x bypass and 1 LPM for the M200EU. Calibration gas flow must be in sufficient excess (~4 LPM) to prevent any ambient air from entering the sample port on the pole.

The maximum 50 ft length of tubing between the Bypass Pump Module and the remote moly converter has been proven to generate too much backpressure for some brands of calibrators. Experience to date is that while NO calibration is correct, GPT can be incorrect due to errors in dilution of the ozone.

We strongly recommend that SPAN CALIBRATION be done with NO span gas. SPAN CHECKS can be done with either NO only, NO₂ only or a mixture of NO and NO₂ (GPT).

Zero air used for all calibration procedures, including GPT, should have <1 ppt NO and NO₂, less than 1 ppt of major interferences such as SO₂, NH₃, hydrocarbons and a dew point of -5°C or less. The calibration gasses should be from a reliable supplier, since the quality of the tank concentration values ultimately determines the accuracy of the analyzer.

NOTE

The M200EU with the NO_y Option does NOT have equivalency approval, and may not be used for EPA monitoring.

4.1 Calibration or Cal Check Procedure

The calibration of the instrument can be checked or adjusted using gas introduced through the calibration port on the Bypass Pump Module. The calibration gas is routed to a TEE near the sample inlet port on the remote converter assembly.

Since the zero gas concentration is defined as 0 ppb, it is not necessary to enter the expected zero value. Table 4.1 details the zero calibration procedure.

Table 4.1 - Manual Zero Calibration Procedure - Zero Gas Thru Sample Port

Step Number	Action	Comment
1.	Press CAL	The M200EU enters the calibrate mode and the adaptive filter is activated. This allows the instrument to respond rapidly to concentration changes regardless of their magnitude.
2.	Wait 10 min	Wait for reading to stabilize at zero value.
3.	Press ZERO	If you change your mind after pressing ZERO, you can still press EXIT here without zeroing the instrument.
4.	Press ENTR	Pressing ENTR actually changes the calculation equations.
5.	Press EXIT	M200EU returns to sampling. Immediately after calibration, data is not added to the DAS averages.

Enter the expected NOx and NO span gas concentrations:

Table 4.2 - Enter Expected Span Gas Concentrations Procedure

Step Number	Action	Comment
1.	Press CAL-CONC-NOX	This key sequence causes the M200EU to prompt for the expected NOx concentration. Enter the NOx span concentration value by pressing the key under each digit until the expected value is set.
2.	Press ENTR	ENTR stores the expected NOx span value.
3.	Press CAL-CONC-NO	Now enter the expected NO span concentration as in step one.
4.	Press ENTR	Pressing ENTR stores the NO span value and returns the prompt to the CONC menu.
5.	Press EXIT	Returns instrument to SAMPLE mode.

If desired, compensation for converter efficiency (CE) can be included in the NOx concentration calculation. Prior to calibration, the converter efficiency should either be set to 1.0 or determined per the procedure in the M200E/EU manual.

Table 4.3 - Span Calibration Procedure

Step Number	Action	Comment
1.	Press CAL	The M200EU enters the calibrate mode and the adaptive filter is activated. This allows the instrument to respond rapidly to concentration changes regardless of their magnitude.
2.	Wait 10 min	Wait for reading to stabilize at span value.
3.	Press SPAN	If you change your mind after pressing SPAN, you can still press EXIT here without spanning the instrument.
4.	Press ENTR	Pressing ENTR actually changes the calculation equations and causes the instrument to read the NO and NOx span concentrations.
5.	Press EXIT	M200EU returns to sampling. Immediately after calibration, data is not added to the DAS averages.

5.0 Maintenance

5.1 Maintenance Schedule

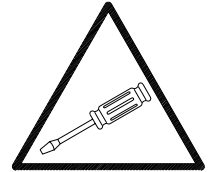

See Table 5.1 below.

Table 5.1- Preventative Maintenance Calendar

Item	Maintenance Interval
Zero/Span Calibration	Annually or after maintenance or repairs
Zero/Span Checks	Daily
Particulate Filter	Weekly as needed
Ozone Flow	Check every year and replace o’ring and orifice in reaction cell
OzoneDryer Filter-DFU	Replace every year
Sample Flow	Check every 2 months
Converter	Check efficiency every 2 months
Pneumatic Lines	Check every 3 months
Factory Calibration	Calibrate each year or after repairs
Leak Check	Check every 6 months
Replace bypass flow orifices	Every year / as needed
Rebuildy bypass pump	Every year

5.2 Replacing the Sample Particulate Filter

The particulate filter should be inspected often for signs of plugging or contamination. It is also common for dirt particles to cause instrument drift, and affect accuracy.

To check and change the filter:

1. Fold down the Bypass Pump Module front panel.
2. Locate the filter on the left side of the analyzer front panel. See Figure 5.1 for an exploded view of the filter assembly.
3. Visually inspect the filter through the glass window.
4. If the filter appears dirty, unscrew the hold-down ring, remove the Teflon o-ring and then the filter.
5. Replace the filter, being careful that the element is fully seated in the bottom of the holder. Replace the Teflon o-ring, then screw on the hold-down ring and hand tighten.

NOTE:

Handle the wetted surfaces as little as possible and clean with cloth prior to assembly

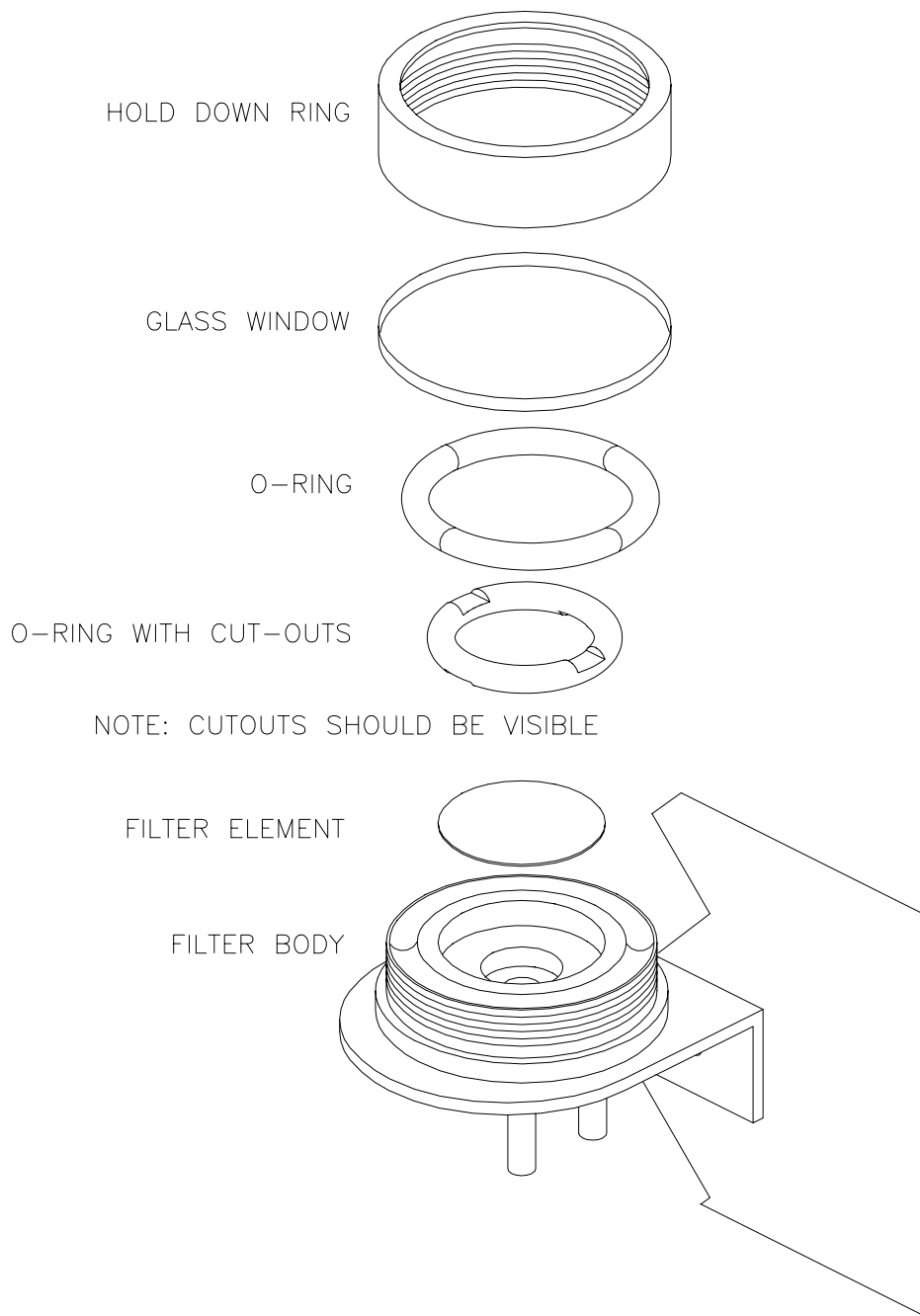

Figure 5.1 - Replacing the Particulate Filter

5.3 Check Bypass Flow Rates

The external sample pump is capable of maintaining the cell pressure at less than 5.0 "Hg-A. If a higher pressure is noted, the pump may need servicing. Check the pump and pneumatic system for leaks or rebuild pump. The ozone scrubber is integrated into the converter case inside the instrument.

See Figure 1.1 for component locations.

5.4 Replacing the Converter

The heater, thermocouple, and converter assembly is designed to be replaced as a single unit. Check Figure 5.2 for component location.

1. Turn off the power to the M501Y at the chassis front panel
2. Allow the converter to cool.

CAUTION!

The converter operates at 315°C. Severe burns can result if not enough time is allowed for the assembly to cool. Do not handle assembly until it is at room temperature.

3. Disconnect the gas fittings and power cable from the can.
4. Remove the entire assembly from the NEMA chassis.
 - A. Remove the pneumatic fittings.
 - B. Remove the converter assembly from the chassis by loosening the 4 captive screws that secures the assembly to the chassis.
5. Remove bottom bracket and re-attach it to the replacement converter assembly.
6. Install the assembly back into the analyzer.
7. Re-attach the electrical and pneumatic fittings. Leak check the assembly when completed.
8. Turn the power back on. The insulation can emit a burnt odor for the first 24 hours, this is normal. Allow the converter to burn-in for 24 hours, then re-calibrate the instrument.

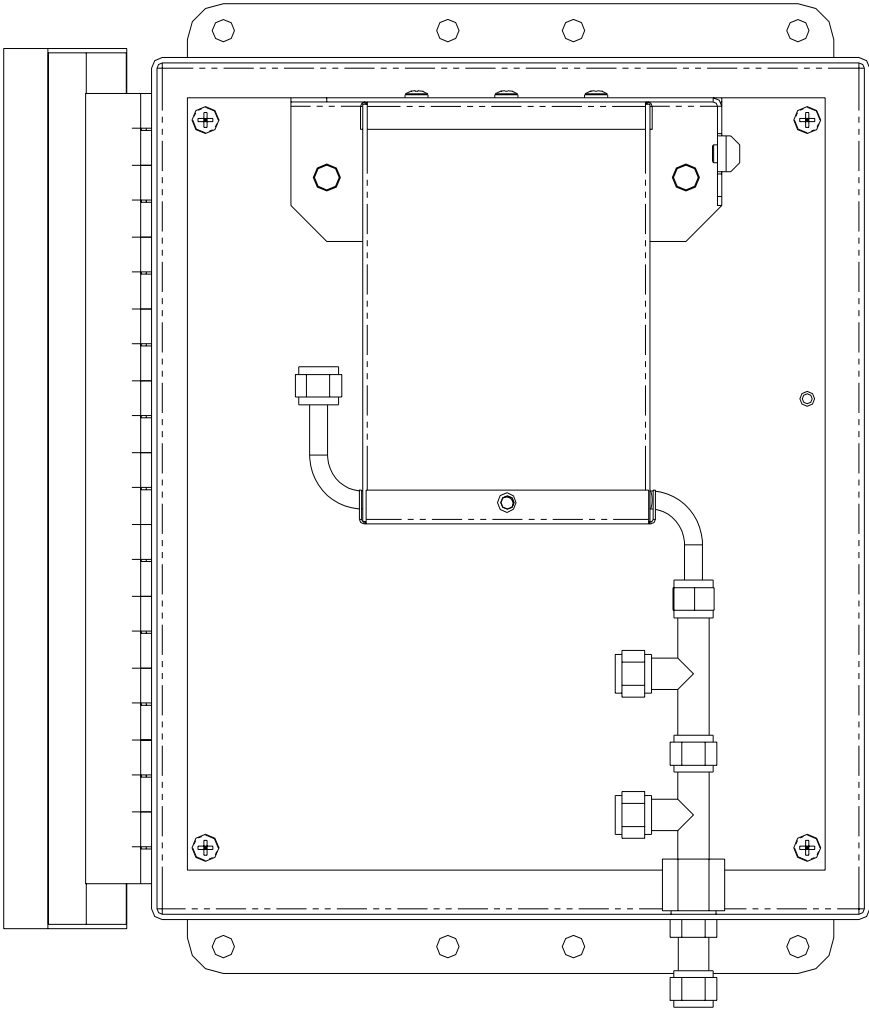

Figure 5.2 - Converter Assembly

5.5 Pneumatic Line Inspection

Particulate matter in the pneumatic lines will affect both flow rate and response time. It is important that the pneumatic system be periodically inspected and thoroughly cleaned if necessary. Clean by disassembling and passing methanol through three times. Dry with nitrogen or clean zero air.

Also inspect all pneumatic lines for cracks and abrasion on a regular basis. Replace as necessary.

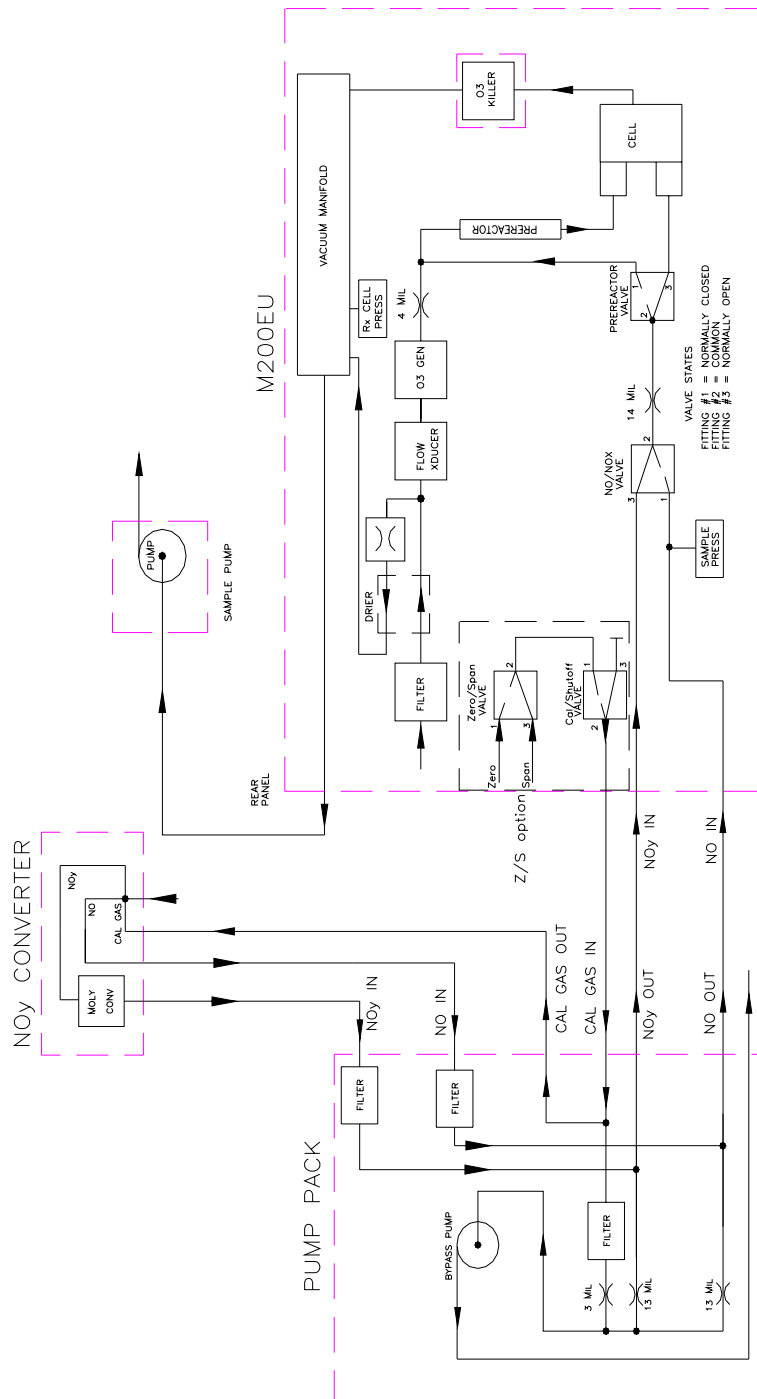

Figure 5.3- Pneumatics diagram (standard and Z/S option)

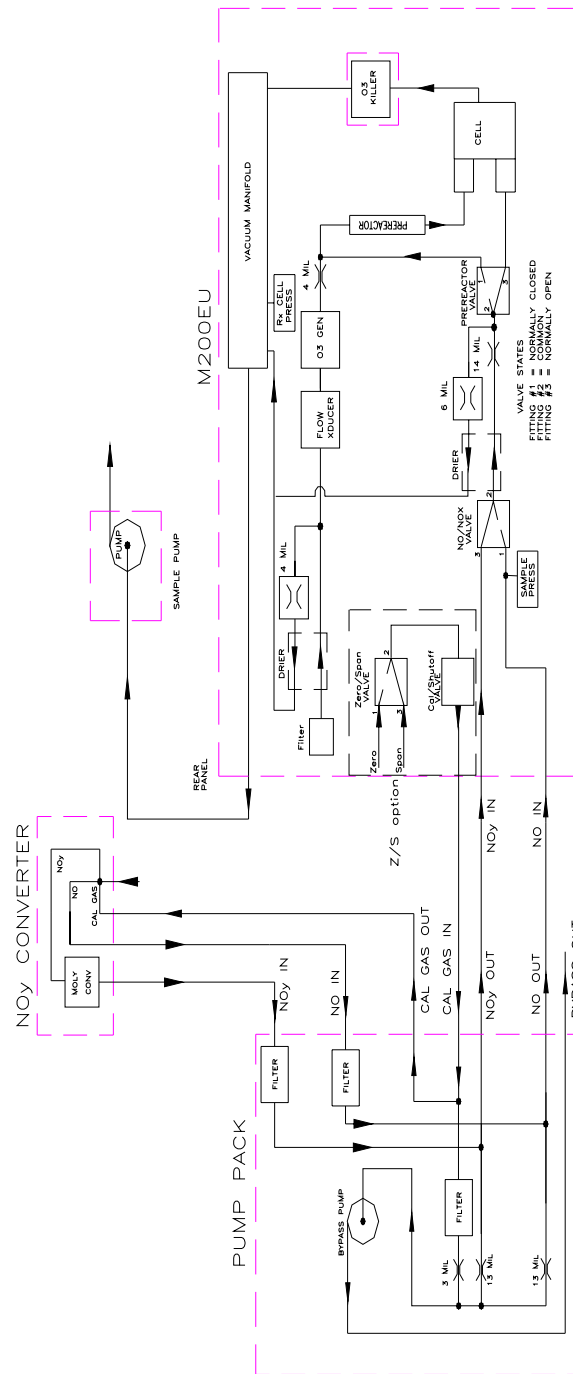

Figure 5.4: Pneumatic diagram (OPT 86 option)

5.6 Leak Check Procedure

Model 200EU-NOy Option Manual Addendum

If a leak checker is not available, it is possible to leak check the instrument using the M501Y's pump plus a shut-off valve.

1. Turn off instrument power and pump power.
2. Cap the sample inlet port, ozone generator air inlet, and zero/span inlets (if Z/S valve option present).
3. Insert a shut-off valve between the sample pump and the vacuum manifold at the rear of the instrument.
4. Turn on the sample pump and set the TEST function to RCEL, which measures the reaction cell pressure. Close the shutoff valve and monitor the cell pressure. The pressure should not drop more than 1"Hg(.5psi) in 5 minutes. If there is a leak, it is not possible by this method to tell where it is located. You can locate the leak by using a pressure leak checker described below.

If you have a leak checker:

1. Turn off instrument power and pump power.
2. Disconnect pump at rear panel. Cap the sample inlet port, ozone generator air inlet, and zero air inlet (if Z/S valve option present) and connect the leak checker to the exhaust port.

CAUTION: PRESSURE MUST BE LESS THAN 15 PSI.

3. Pressurize system and check for leaks by watching overall pressure. The pressure should not drop more than 1"Hg (.5psi) in 5 minutes.

If the instrument fails the pressure test, each fitting needs to be leak checked to find the location. Be careful that the system is always pressurized so as not to draw soap solution into the plumbing system. Make sure you dry off any accumulated bubble solution.

The Sensor module can be leak checked as a unit using a 1/8" tubing fitting on top of the assembly. The same rules as above apply.

6.0 Troubleshooting, Adjustments



NOTE

THE OPERATIONS OUTLINED IN THIS CHAPTER ARE TO BE PERFORMED BY QUALIFIED MAINTENANCE PERSONNEL ONLY!

This section of the manual contains information on diagnosing and repairing converter performance problems.

This Section provides troubleshooting procedures that address problems to the board level. For component level troubleshooting, consult the schematics for the appropriate board in the Appendix.

6.0.1 General Troubleshooting Hints

1. Think of the M501Y as two sections:
 - A. Section 1 - Pneumatics - Over 50% of all instrument problems are traced to leaks in the M200EU, pump assembly, pole mounted converter assembly, sample filter, or zero/span gas delivery system (calibrator). Suspect a leak first.
 - B. Section 2 - Electronics – converter temp control board or DC power supply for the converter temperature readout.
2. Incorrect span gas concentration - this could come either from the calibrator or entering the expected span gas concentration in the M501Y incorrectly.
3. If the instrument does not respond to span gas, check troubleshooting section in the M200E/EU manual.

The above should get you started in diagnosing and repairing the most common faults. If these reasons have been eliminated, the next thing to do is a Factory Calibration covered in M200E/EU manual. If difficulties persist, contact our service department. The 800 telephone number is on the cover page of this manual.

6.1 Operation Verification - M501Y Diagnostic Techniques

6.1.1 Pneumatic System

The pneumatic system is diagramed in Figure 5.3.

6.1.2 Leak Check

Refer to Section 5.6 for the leak check procedure.

6.1.3 Bypass Pump Diagnostic Procedures

The bypass pump is capable of maintaining a total bypass flowrate of 4 lpm. If flow checks indicate a fall off in bypass flow, the pump may need servicing. Check the pump, inlet fittings, and analyzer for leaks first. If other causes have been eliminated, rebuild the pump.

6.1.4 Electrical Fault Isolation

115 VAC is supplied to:

1. The bypass pump.
2. The +5 volt switcher supply.
3. The input power to the converter temperature controller.

Use Figure 6.1 to check the 115 VAC supply voltage to each of these components.

The switcher supply produces 5 VDC to power the front panel display. Use Figure 6.1 to check the 5 VDC supply voltage to the display.

The converter temperature is controlled by the 002560100 assembly in the NEMA chassis. The 00257 schematic is located at the back of this manual.

The converter temperature controller produces ± 15 VDC to power the controller logic. The OPTO ISOLATOR component switches the 115VAC to the heater. Check the heater element for continuity. The DS1 LED is on when power is applied to the heater. Check for appropriate voltages. The temperature is sensed by a thermocouple attached to TB1. Typical thermocouple voltage at the 315°C setpoint is about 16 mV. U1 provides cold junction compensation and linearizes the output of the thermocouple. The output of pin 8 on U1 is 1/100 of the temperature. In other words 3.15 VDC represents 315°C.

6.2 Setting the Converter Temperature

A front panel-mounted programmable controller maintains the temperature of the remote molybdenum converter. By pressing the PV/SV button in the lower left corner of the controller, you can see the Present Value (actual temperature) or the Set Value (temperature set point). The temperature and PID control parameters have been set at the factory and no further adjustment should be necessary. Should you need to adjust the temperature, follow these steps:

1. Select SV with the PV/SV button,
2. Press the "up-arrow" under the digit you want to change,
3. (the digit will flash),
4. Press the "up-arrow" under the digit or the "down-arrow" at the left to scroll the digit to the desired value,
5. Repeat for the other two digits,
6. Press the ENTER button.

Select PV with the PV/SV button to observe the actual temperature.

6.1.4 Temperature Controller Setup

The temperature controller has been programmed at the factory and should not need to be altered under normal usage.

Indications that would require re-programming are:

- Failure / replacement of controller
- Replacement of thermocouple element
- Controller's loss of PID parameters leading to instability of the temp setpoint.

In the event that the control parameters are changed or in the event that a new controller is installed, it must be reprogrammed to suit the thermal characteristics of the instrument. The controller includes an Autotuning feature, which can be used to properly set the PID factors. To start Autotune procedure:

- Press Sel until A7 (AT) is displayed
- Press Data until value = 1 (enable Autotune)
- While Autotuning, the decimal point will blink.
- NOTE: During the procedure, it is normal for the temp to overshoot up to 100°C.
- When the decimal point LED turns off, Autotune is complete. No further adjustment should be necessary.

Table 6.1 – Temperature Controller Programming Guide

PRESS	DISPLAY	ACTION
SEL X2 DATA	P PROP BAND	UP/DOWN SET TO 5.0 (ENTER)
SEL DATA	i INTEGRAL	SET TO 50
SEL DATA	d DERIVATIVE TIME	SET TO 5
SEL DATA	7C CYCLE TIME 30 DEFAULT	SET TO 15 (FOR FAST SYSTEM)
SEL	HYS HYSTERESIS	SET TO 0.3
SEL	5rr RAMP RATE	SET TO 0
SEL DATA	A7 AUTOTUNE	SET TO 1 = ON
SEL	LOC LOCK	0 = OPEN 1 = LOCKED 2 = SV ONLY OPEN
SEL	END RETURNS TO SV.	SET TO 315 (315°C SET VALUE)

NOTE:
DO NOT SET THE TEMPERATURE (SV) HIGHER THAN 320°C.

SECONDARY MENU (The fixed characteristics of the system).

PRESS	DISPLAY	ACTION
SEL	HOLD TILL p-n1	SET TO 0 – REVERSE ACTION
SEL	HOLD TILL p-n2	SET TO 2 = TYPE J THERMOCOUPLE
SEL	p-dF DIGITAL FILTER	SET TO 5
SEL	P-SL LOWER LIMIT	DEFAULT = 32
SEL	P-SU UPPER LIMIT	SET TO 350 (350°C)
SEL	P-Ab ALARM	NONE
SEL	P-An HYTERESIS	NONE
SEL	P-dP PROG DECIMAL	SET TO 0
SEL	P-48 COLD JUNCTION	SET TO 2 (TYPE J)
SEL	r5 RAMP TO SET POINT	LEAVE AT 0
SEL	PVOF PROCESS OFFSET	LEAVE AT 0
SEL	SVOF SET POINT OFFS	LEAVE AT 0
SEL	P-F	SET TO 0 (0 = °C, 1 = °F)
SEL	P-n1	
SEL	HOLD TILL P	
SEL	SCROLL TO A7	SET TO 1 (AUTOTUNE)
SV	SET VALUE	SHOULD BE 315°C

7.0 M501Y Spare Parts List

Note: Use of replacement parts other than those supplied by API may result in non-compliance with European Standard EN 61010-1.

PART NO.	DESCRIPTION
00094-4	ORIFICE, 4 MIL 80 CC, O3 FLOW Rx CELL
00094-10	ORIFICE, 13 MIL 1100 CC, Rx CELL
01630-04	SAMPLE FILTER ASSY
02315	SENSOR ASSY, M501Y, EXCHANGE
01872	WELDED CONVERTER W/ O3 KILLER
02293A	OPERATORS MANUAL FOR M501Y
01357	THERMOCOUPLE ASSY
02317	M501Y EXPENDABLES KIT
02318	M501Y LEVEL 1 SPARES KIT
00969	FILTER, TFE, 47 mm Quantity 100
00969-1	FILTER, TFE, 47 mm Quantity 25
02230	DC POWER SUPPLY BOARD
PS004	5, ±15 VDC, SWITCHING POWER SUPPLY
01086	STATUS/TEMP BOARD
00728	DVM DISPLAY
01198	ASSY, THERMOCOUPLE
01236	FAN, BYPASS PUMP CHASSIS
01314	FAN, PMT COOLER
FL001	SINTERED FILTER
FL003	FILTER, DFU
01068	HEATER, CONVERTER
HW020	SPRING, FLOW CONTROL
HW036	TFE THREAD TAPE (48 FT)
HW037	TIE, CABLE
OR058	O-RING, SAMPLE FILTER
01631	RETAINING RING, SAMPLE FILTER
OR034	O-RING, FITTING
PU028	SAMPLE PUMP, M501Y
PU030	SAMPLE PUMP REBUILD KIT